



**400 HZ ELECTRICAL DISTRIBUTION
SYSTEMS**

By

J. Paul Guyer, P.E., R.A.

PDHLibrary Course No 0010023
3 PDH HOURS

J. Paul Guyer, P.E., R.A.

Paul Guyer is a registered civil engineer, mechanical engineer, fire protection engineer and architect with 35 years of experience designing buildings and related infrastructure. For an additional 9 years he was a principal staff advisor to the California Legislature on capital outlay and infrastructure issues. He is a graduate of Stanford University and has held numerous national, state and local offices with the American Society of Civil Engineers, Architectural Engineering Institute and National Society of Professional Engineers.

CONTENTS

1. INTRODUCTION

2. GENERAL CONSIDERATIONS

3. DESIGN REQUIREMENTS

(This publication is adapted from the *Unified Facilities Criteria* of the United States government which are in the public domain, have been authorized for unlimited distribution, and are not copyrighted.)

(Figures, tables and formulas in this publication may at times be a little difficult to read, but they are the best available. **DO NOT PURCHASE THIS PUBLICATION IF THIS LIMITATION IS UNACCPETABLE TO YOU.**)

1. INTRODUCTION

1.1 SCOPE. This discussion includes information necessary for the proper design of 400-Hertz (Hz) conversion, distribution, and utilization systems. Special regard is paid to systems utilizing medium-voltage distribution.

2. GENERAL CONSIDERATIONS

2.1 USAGE. Aerospace electrical equipment generally operates at an input of 400 Hz. Electrical power is supplied by aircraft generators, which normally receive their energy from the aircraft engines. Three-phase aircraft generators deliver 3,000 to 4,000 RPM, depending upon engine speed, which is synthesized into 400-Hz output voltage for distribution to aircraft equipment. Large aircraft may have several hundred electric motors, and the use of 400 Hz provides a considerable weight saving. Three-phase, 400 Hz, open-frame units (1 to 15 horsepower in size, with speeds of 12,000 to 24,000 revolutions per minute) developed for aircraft have weights averaging 2 pounds per horsepower (0.9 kilograms per horsepower). An open, dripproof, 60 Hz, 1,800 revolutions-per-minute unit of one horsepower weighs about 40 pounds (18 kilograms).

2.2 TYPES OF SYSTEMS. Systems supplying 400 Hz for ground-power operations use frequency conversion equipment to change 60-Hz input to 400-Hz output. Rotary converters (motor generator sets) or solid state converters are used for this purpose. Fixed service point units to which avionics equipment and aircraft are connected are supplied from either nearby frequency conversion assemblies over a low-voltage feeder system or from a more remotely located 400-Hz central plant using medium-voltage feeders.

2.2.1 ROTARY CONVERTERS. Rotary converters or motor generator (MG) sets are used for both low and medium voltage systems. These units are usually limited to installation in industrial locations due to the high level of noise produced.

2.2.2 SOLID STATE CONVERTERS. Solid state converters are used only for low-voltage systems. The noise levels produced by these units as compared to MG sets are substantially less. The industry trend is to replace rotary machinery with solid state converters.

2.3 DISTRIBUTION SYSTEMS. Fixed service point units to which avionics equipment and aircraft are connected are supplied from either nearby frequency conversion assemblies over a low-voltage feeder system or from a more remotely located 400-Hz central plant using medium-voltage feeders.

2.3.1 LOW-VOLTAGE SYSTEMS. Generally low-voltage systems distribute voltages less than 600 volts. Because the reactance of an electric system is greater at 400 Hz than at 60 Hz, attention must be given to both circuit length and conductor size to maintain acceptable voltage regulation. Consequently, when loads and distribution distances increase, low-voltage systems require use of excessive feeder sizes and installation of numerous local frequency conversion assemblies. When numerous local frequency conversion assemblies are used, the reliability of the system is increased. A typical, 400 Hz low-voltage system is shown on Figures 1a and 1b. Detailed requirements are provided in Appendix B.

2.3.2 MEDIUM-VOLTAGE SYSTEM. The development of a medium-voltage system which distributes three-phase, 400-Hz electric power at 4,160 volts can provide a more economical system. A typical, 400-Hz medium-voltage system is shown on Figure 1.

2.3.3 FLIGHT-LINE ELECTRICAL DISTRIBUTION SET (FLEDS). A FLEDS system may be used in conjunction with the low-voltage or medium-voltage system. The components of an individual FLED set are shown in Figure 1c. A FLED system consists of a number of FLED sets which distribute 200Y/115 volts at 400 Hz to a maximum of two aircraft per FLED set.

2.4 SURVEYS. Before replacing existing local low-voltage systems with a central medium-voltage system, make preliminary surveys to ensure the cost effectiveness of the replacement.

2.4.1 ENERGY CONSERVATION. Full load efficiency of the motor-generator set portion of frequency conversion assemblies ranges from 73 to 88 percent, depending on the size of the sets and the type of motor drive (induction or synchronous). The use of many sets, operating underloaded, lowers efficiencies, increases energy usage and cost, and probably increases maintenance and shortens operating life.

2.4.2 ECONOMIC STUDIES. When preliminary surveys and studies indicate that a central system may be economically feasible, a complete life-cycle cost analysis may be necessary. Make field measurements of the actual demand loads on each existing low-voltage 400-Hz system. Determine power requirements, characteristics, and locations of all existing utilization equipment and service points. The using agency shall advise of any changes in load requirements contemplated to serve anticipated mission changes so that this information may be included in determining the capacity required for a central system.

2.5 TYPES OF LOADS. Various types of loads require 400-Hz electric-power input. The power factor of these loads varies from 0.8 to 1.0.

2.5.1 AIRCRAFT. The number of each type of aircraft serviced determine the total demand. For computation of 400-Hz aircraft loads, use the maximum load in Table 1 with a demand factor applied to the total load as given in Table 2.

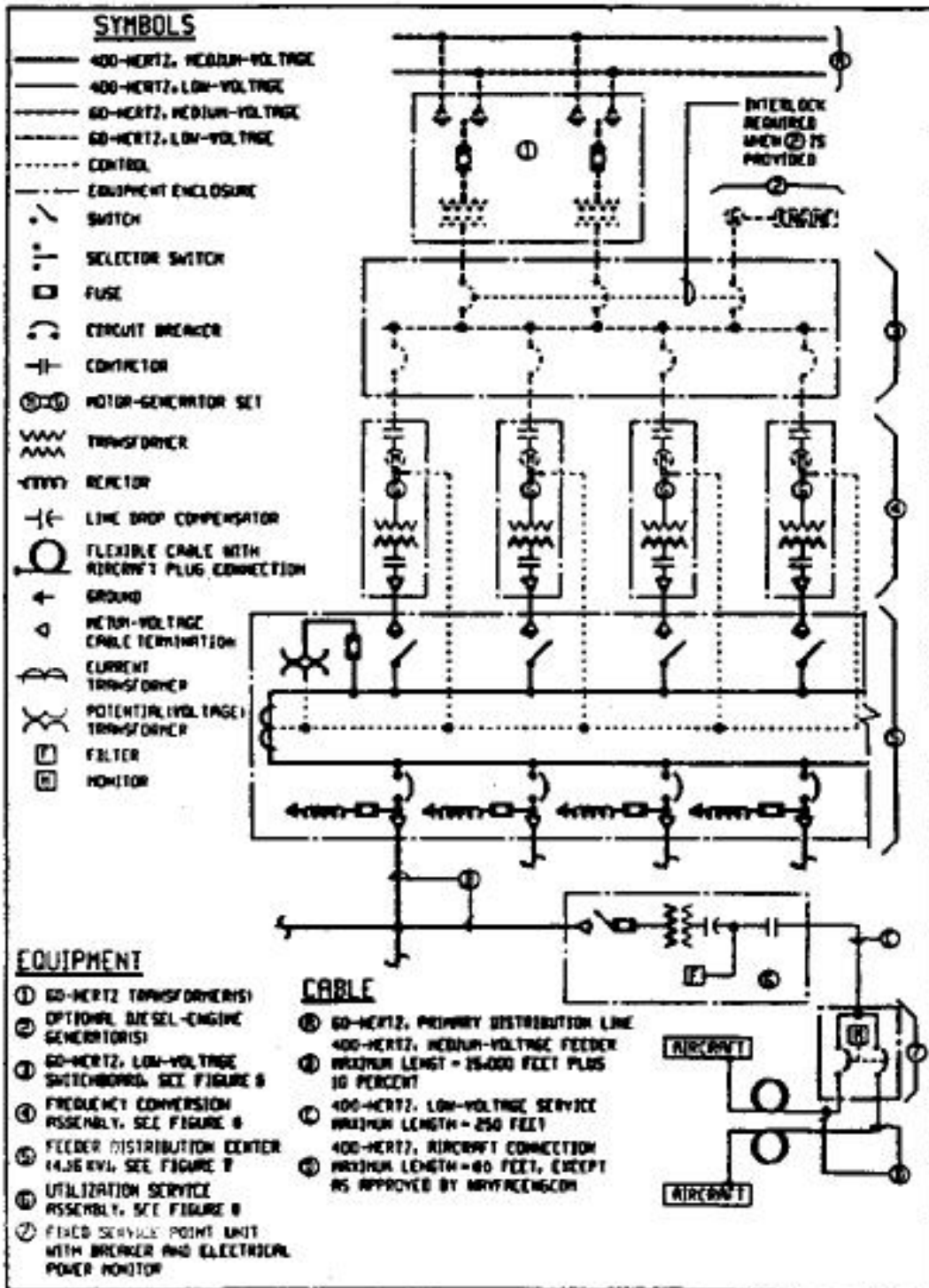

Figure 1a
 Typical 400 Hz medium voltage system

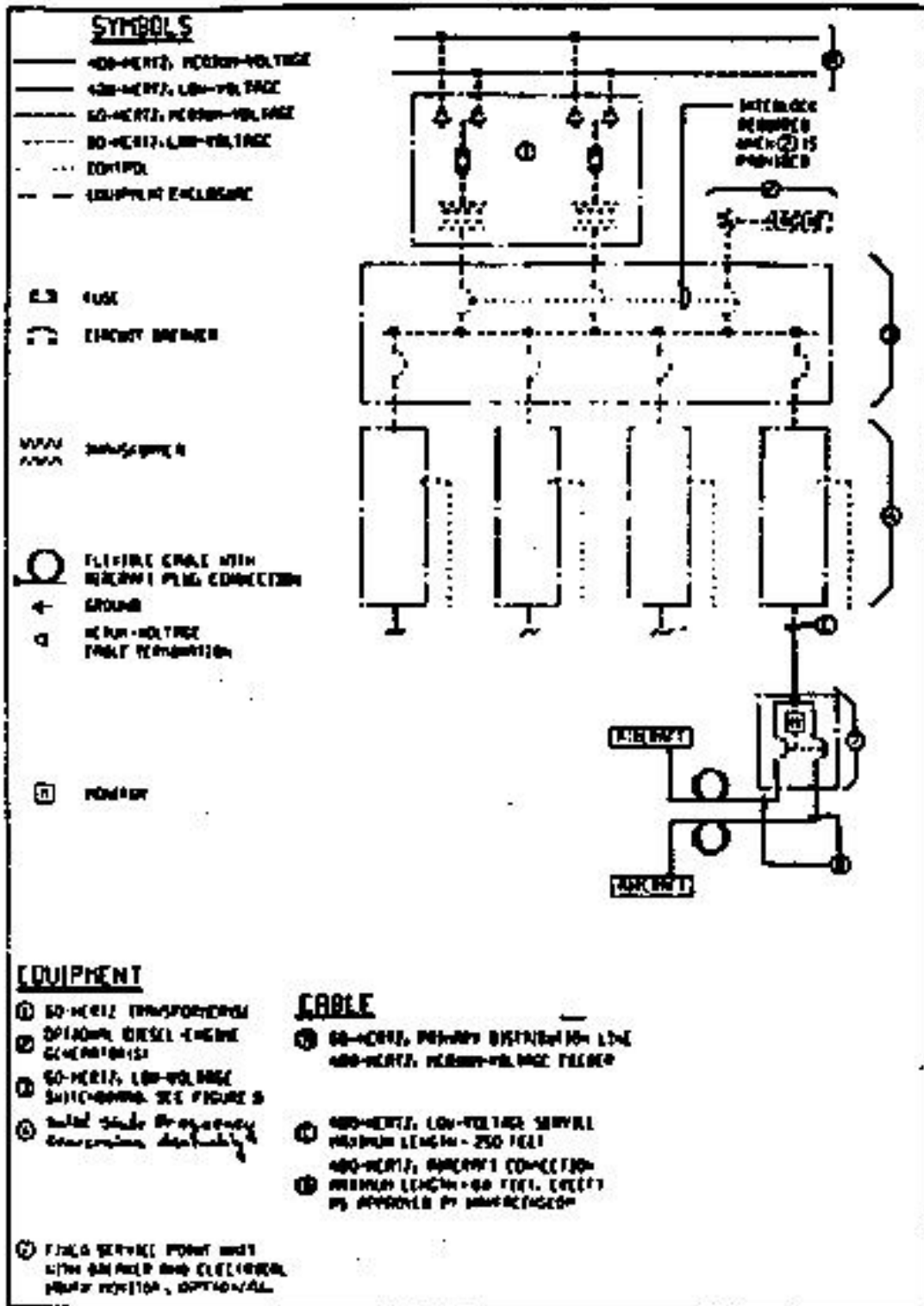

Figure 1b
Typical 400 Hz low voltage system

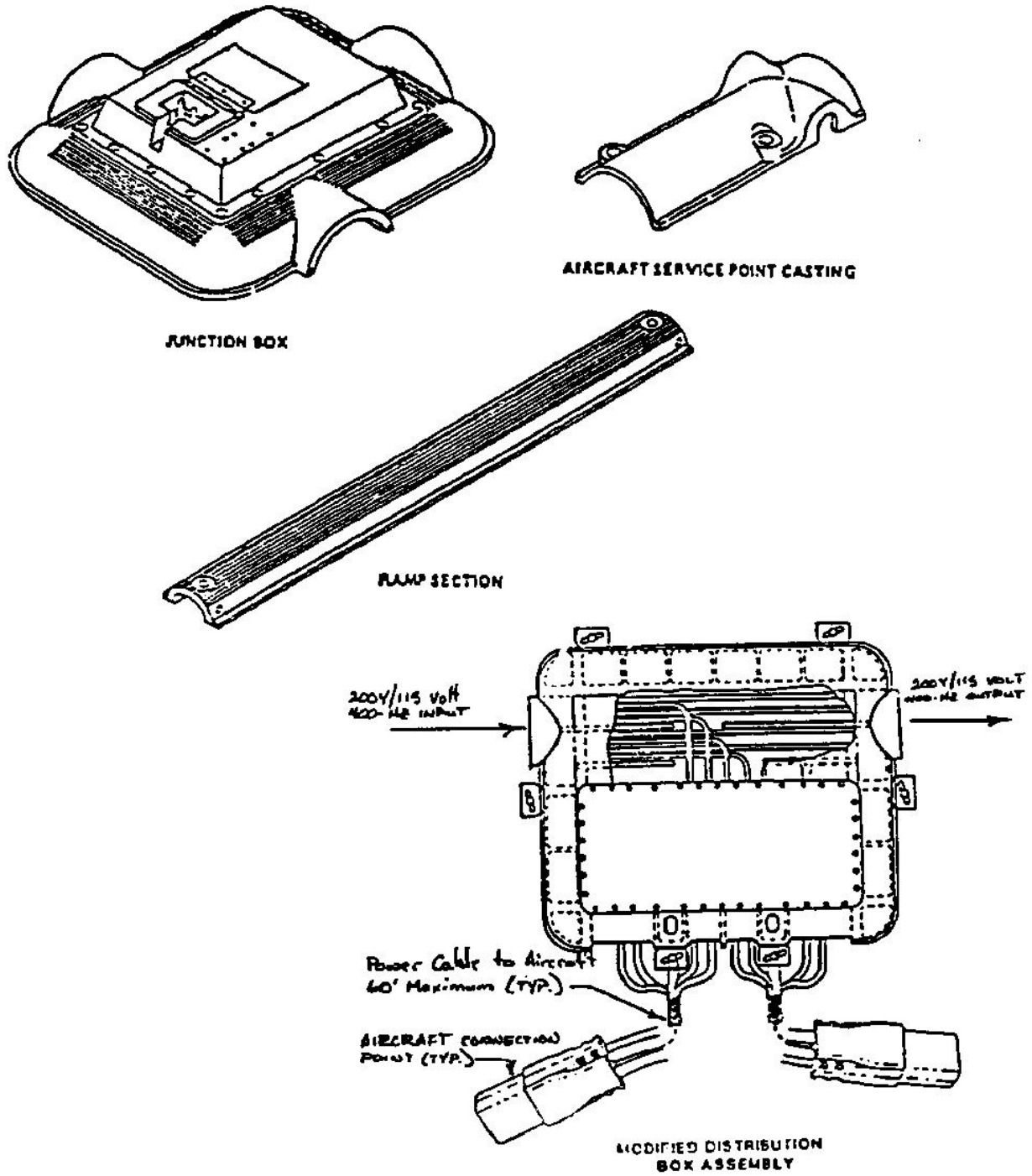
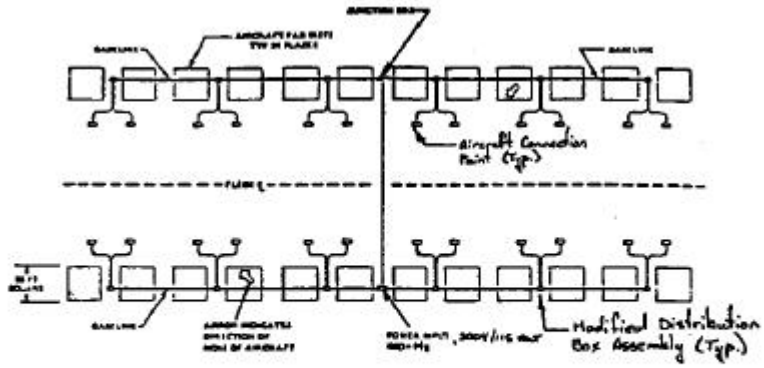
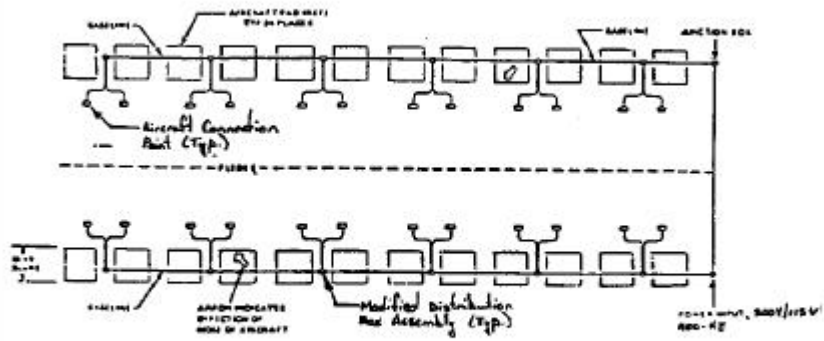

Figure 1c

Major components of Flight Line Electrical Distribution (FLED) system



EXAMPLE 1



EXAMPLE 2

Figure 1d

Examples of a typical FLED system

Aircraft Load Type	Maximum kVA
A-4E	2.7
A-6E	12.2
E-2C	86.2 **
E-6A	400 *
F-4J	23.5
F-14A	17.3
F-18	18.5
P-3C	70.8
S-3A	33.9
EA-6B	17
HH-3D	16.5
SH-60B	15.5
SH-60F	15.5
EGC-130	42.3
C/MH-53E	16

* four service cables required

** two service cables required

Table 1
Representative 400 Hz aircraft loads

Number of Aircraft	Demand Factor Percent
1	100
2	90
3	83
4	77
5	71
6	66
7 to 9	61
10 to 12	50
13 to 15	45
16 to 21	40
22 to 40	31
41 to 60	28
Over 60	25

Table 2
Representative system demand factors

2.5.2 AVIONICS. In addition to aircraft, other loads such as repair shops for electronic equipment, require 400-Hz electric power for maintenance and testing. Load requirement shall be provided by the Owner in such cases.

2.5.3 OTHER FACILITIES. Research, development, training, and other types of facilities may require 400-Hz distribution systems. If the Owner cannot provide load requirements, compute such loads on a watts per square foot (square meter) basis when firm loads are not available.

2.5.4 SPECIAL REQUIREMENTS. Facilities indicated above may have more stringent 600-Hz power requirements than the Fixed Point Utility System (FPUS) provides. Prior to supplying these facilities from FPUS, verify that equipment installed will not be damaged by FPUS power tolerances. Use local converters for these systems.

2.6 CONSIDERATION OF SYSTEM VOLTAGE PARAMETERS. The inductive contribution to the reactance voltage drop of 400-Hz systems is roughly seven times greater than that of 60-Hz systems, which necessitates certain modifications to conventional distribution and utilization system design to compensate for the increased voltage drop. Specifications for limiting voltage drop are covered in later sections, but the following requirements apply generally to 400-Hz systems.

2.6.1 DEVELOPMENT OF GUIDELINES FOR PARAMETERS. Voltage drop is always a concern in the design of 60-Hz systems. Give even closer attention to voltage parameters in the design of 400-Hz systems because the voltage drop is much larger. When designing 400 Hz systems, take into account the effects of varying cable lengths and connected loads.

2.6.2 ITEMS AFFECTING DESIGN. The designer must consider maximum loads and applicable cable-length limitations. Based on acceptable end-voltage requirements, determine maximum allowable cable and equipment impedances. Methods to be used for compensation or elimination of impedance are important also. Overcompensation of

voltage drop can be as bad as under compensation. The voltage range which provides satisfactory aircraft power is the key element to an acceptable 400-Hz distribution system.

2.6.2.1 ACCEPTABLE END-VOLTAGE REQUIREMENTS. The voltage range of 108 volts minimum to 118 volts maximum specified is the operating voltage range of the equipment inside the aircraft. This operating voltage range takes into account a 0- to 5-volt drop in the electrical distribution system inside the aircraft. Accordingly, the full-load and no-load voltage at the interface (aircraft connection input point) should never drop below 113 volts nor rise higher than 118 volts. These parameters also apply to the input to the FLEDS system.

2.6.2.2 EQUIPMENT AND CABLE PARAMETERS. Rotary equipment and cable parameters for use by the designer are given in Tables 3, 4, and 5. Some parameters directly affect voltage drop; other parameters are provided for information only. Equipment and cable descriptions correspond to those shown on Figure 1. These values are used to determine the maximum cable lengths (e.g., medium voltage feeders and low-voltage service circuits and aircraft cable connections), plus the permissible number of unit loads per feeder cable. Equipment providing lower voltage-drop parameters is acceptable.

2.6.2.3 UNIT LOADS. The unit-load basis used herein for voltage-drop calculations is individual 100-ampere, 0.8-power-factor loads. Two 100-ampere unit loads can be supplied by a 75-kVA utilization service center.

2.6.3 MAXIMUM CABLE LENGTH AND LOADS. To determine maximum cable length and loads and the effects of other system parameters, various conditions were analyzed. Table 6 shows the maximum number of unit loads that can be connected to a medium-voltage feeder and meet minimum voltage levels at the utilization service assembly.

2.6.3.1 ALLOWABLE MEDIUM-VOLTAGE DISTRIBUTION LEVEL. Provide the medium-voltage distribution level of 4,160 volts. Commercial airports are using 400-Hz systems with voltages up to 2,400 volts. However, in these cases the feeder lengths (or distances) are much shorter than the feeder lengths on the systems used by military airfields.. The 2,400-volt system provides no appreciable cost savings although it requires a reduction of the maximum feeder length to one-third of that acceptable on a 4,160-volt system which serves the same load. If feeder lengths are not reduced, then the 2,400-volt system is capable of serving only one-third of the load that can be fed by a 4,160-volt system.

2.6.3.2 MAXIMUM CABLE LENGTHS. Normally, do not exceed cable length values given in Table 7 for medium-voltage cables and in Table 8 for low-voltage cables. The reason that only four unit loads were permitted in Table 7 is that the effects of the low-voltage cables were considered. This was not the case in Table 6. The use of four loads maximum means that the steady-state load plus the step-load can never exceed 400 amperes as shown in the step-load capability columns.

2.6.3.3 EXCEEDING LIMITING CABLE LENGTHS. Justify exceeding the normal cable length limits only as follows:

- a) When the limitation requires another central plant, the 15,000-foot feeder cable length may be increased by 10 percent. Increases over 5 percent must be approved by the Owner.
- b) Due to special site conditions, the aircraft cable length at such sites may be increased to 70 feet in length, only if approved by the Owner.

2.6.3.4 RATIONALE OF MAXIMUM CABLE LENGTHS. The essential factor in determining acceptable cable lengths is the 113-volt limitation at the aircraft interface point. Meet this limitation in the following manner:

- a) Permit a steady-state voltage droop to 3,918 volts on the 4,160-volt end of the medium-voltage distribution system. Droop is defined as the absolute change in voltage between the steady-state no-load condition and the steady-state full-load condition. This equates to 113 volts on the low-voltage distribution system or 0.942 per unit volts (using base voltages of 4,160 volts and 120 volts) at the terminals of the utilization service assembly.
- b) Make up for the low-voltage system droop by compensating for the low-voltage system's reactance.

1. Synchronous Units with Revolving Fields		
	Motor	Generator
Power Factor	1.0	0.8
Voltage	460 volts	575 volts
Frequency	60 hertz	400 hertz
Full load		
Synchronous Unit Current	420 amperes	314 amperes
Field current	8.86 amperes	26.7 amperes
Current to bridge air gap	3.9 amperes	17.01 amperes
No Load		
Field current	3.8 amperes	14.435 amperes
Current to bridge air gap	3.6 amperes	14.03 amperes
Number of poles	6	40
Full load rating	400 horsepower	312 kVA
Synchronous speed	1,200 rpm	1,200 rpm
2. Transformer		
Rating		312 kVA
Voltage	575 to 4,160 volts	
Resistance		1 percent
Reactance		5 percent
Current base	313.3 to 43.3 amperes	

Table 3
Frequency conversion assembly parameters

1. Transformer			
Rating			75 kVA
Voltage		4,160 to 208Y/120 volts	
Resistance			1 percent
Reactance			5.9 percent
Current base		10.4 to 208 amperes	

2. Line Drop Compensator			
Rating	90 kVA	Rating	75 kVA
Voltage	208Y/120 volts	Voltage	208Y/120 volts
Compensation		Compensation	
5 percent	-j.024 ohms	6 percent	-j.034 ohms
6 percent	-j.029 ohms	8 percent	-j.046 ohms
7 percent	-j.034 ohms	10 percent	-j.058 ohms
8 percent	-j.039 ohms	12 percent	-j.069 ohms
9 percent	-j.042 ohms	14 percent	-j.081 ohms
12 percent	-j.058 ohms	16 percent	-j.092 ohms
14 percent	-j.067 ohms		
16 percent	-j.077 ohms		
18 percent	-j.086 ohms		
20 percent	-j.096 ohms		

3. Passive-Element Filter	
Resistance	0.6 ohms
Reactance	2.3 millihenries
Capacitance	68 microfarads

Table 4
Utilization service assembly parameters

1. Medium-Voltage Feeder Cable	
Size	No. 2 AWG
Conductors	one 3-conductor
Voltage rating	5 kV at a 100 percent insulation level
Insulation Type	EPR or XLP
Cable assembly impedance values per 1,000 feet:	
Resistance	0.098 ohms
Inductance	101 microhenries
Capacitance	0.1142 microfarads

2. Low-Voltage Service Cable	
Size	4/0 AWG
Conductors	one 3-conductor
Voltage rating	600 volts
Insulation Type	XHHW
Cable assembly impedance values per 1,000 feet:	
Resistance	0.085 ohms
Inductance	70.8 microhenries
Capacitance	0.0962 microfarads

Table 5
Cable parameters

Cable Length Feet	Bus 3 Per-Unit Volts (2)	Number of Unit Loads	No-Load Volts 1-n
15,000	0.9917	One	119
	0.9834	Two	118
	0.9751	Three	117
	0.9668	Four	116
	0.9585	Five	115
	0.9502	Six	114
	0.942	Seven	113
10,000	0.9945	One	119.3
	0.9890	Two	118.7
	0.9835	Three	118.0
	0.9780	Four	117.4
	0.9725	Five	116.7
	0.9670	Six	116.0
	0.9610	Seven	115.3
	0.9560	Eight	114.7
	0.9505	Nine	114.0
	0.9450	Ten	113.4
5,000	0.9973	One	119.6
	0.9919	Three	119.0
	0.9865	Five	118.4
	0.9811	Seven	117.7
	0.9757	Nine	117.1
	0.9703	Eleven	116.4

- (1) Voltage regulated on the high-voltage side (4,160 volts) of the frequency conversion transformer assembly.
- (2) The utilization service center transformer per-unit base is 208/120 volts. See Appendix A for detailed analysis of the system.
- (3) The underlined rows denote the maximum number of unit load wherein voltage does not drop below 113 volts.

Table 6
Maximum Unit Loads on Feeders (1)

Feeder Cable Length Feet	Individual 100-Ampere, 0.8-Power-Factor, Steady State Unit Loads	Step Load Capability at 0.8 Power Factor	
		Steady State Load Amperes	Step Load Addition Amperes
15,000	4	0	400
		100	300
		200	200
		300	100
		400	0

Table 7
Maximum 400-Hertz Medium-Voltage Cable/Lengths and Loads

Service Cable Length Feet	Aircraft Cable Length Feet
250	60

(1) Based on a 100-ampere, 0.8-power-factor unit load.

Table 8
Maximum 400-Hertz Low-Voltage Cable Lengths (1)

3: DESIGN REQUIREMENTS

3.1 DESIGN PROCEDURES. Preliminary design procedures for 400-Hz systems are the same as those for 60-Hz systems (loads, distances, etc.) so that the system design will meet project requirements.

3.1.1 DATA GATHERING. Determine the following data regardless of whether an entirely new installation is being designed or an existing facility is being changed or upgraded. While a new facility allows more leeway in the design approach, the available load data ordinarily will not be as precise. Gather or design concurrently with the 400-Hz system the following data:

- a) Facility electrical site plans with locations of all aircraft service points.
- b) Facility electrical building plans having 400-Hz loads or used to house 400-Hz equipment.
- c) Determination of all 400-Hz load specifications including both requirements for new loads and replacement or reuse of any existing 400-Hz low-voltage conversion distribution system.
- d) Data on the proposed or installed 60-Hz primary distribution system.

3.1.2 SYSTEM LAYOUT. From the above data, develop a system layout which locates possible distribution line choices and pinpoints load connection points.

3.1.3 EQUIPMENT LAYOUT. After the development of the system layout, make equipment locations based on the design aspects delineated in the following paragraphs.

3.1.4 DESIGN ASPECTS. The 400-Hz system consists of the following major elements:

- a) The central power plant.
- b) The medium-voltage distribution system.
- c) The low-voltage utilization system.

The following considerations apply to the entire 400-Hz system design.

3.1.4.1 PROTECTIVE DEVICE OPERATION. Always consider the thermal and magnetic characteristics for 400-Hz circuit protective devices. Operation at 400 Hz causes more heat rise in current-carrying parts than does operation at 60 Hz. There is also decreased electromagnetic pull on magnetic-trip elements. Because all current ratings of devices are affected to different degrees, consider applicable derating factors during design phase. Check with the appropriate manufacturers to determine ratings appropriate to the equipment. Also, specially calibrate thermal and magnetic characteristics of protective devices for use on 400-Hz systems.

3.1.4.2 SURGE ARRESTERS. Provide Surge arresters for 60-Hz system protection where necessary. In general, the only exposed lines will be those of the 60-Hz distribution system. Therefore, provide 400-Hz protection only for devices whose insulation capability is below that provided by the 60-Hz surge protection, which will normally protect the medium-voltage 400-Hz devices. Varistors available for use with the low-voltage 400-Hz system can limit surges to about 1.7 times the peak voltage; provide where required. The using agency will furnish details of any equipment requiring other than varistor protection. For 400-Hz electronic equipment sensitive to voltage spikes as low as 1.5 times the nominal voltage, zener-type suppressors (silicon-

avalanche diodes) can limit the voltage to 1.38 per unit. Provide these zener-type suppressors normally on the equipment terminals.

3.1.4.3 BUS AND CABLE MATERIAL. Because of its lower resistance, use copper, except where such use is clearly impracticable. Fully justify the use of anything other than copper in the design analysis.

3.1.4.4 CONDUIT. The presence of magnetic materials in the vicinity of electric conductors increases the flux density thereby increasing resistance and inductance. Therefore, use nonmagnetic materials, such as aluminum or plastic, for all raceways. Use nonmagnetic materials, such as aluminum, bronze, or plastic, as appropriate, for cable terminations, cable clamps, and other equipment.

3.2 MEDIUM-VOLTAGE DISTRIBUTION SYSTEM DESIGN. Because the 15,000-foot maximum feeder length dictates the number and location of acceptable central plant sites, make the layout of the medium-voltage feeder lines first.

3.2.1 TYPE OF DISTRIBUTION. Generally, use raceway systems for distribution of 400-Hz circuits. Bare, aerial 400-Hz systems are precluded because of the excessive inductance of such circuits. Overhead distribution systems using preassembled, messenger-supported, insulated cable are acceptable in areas where lightning storms are few and where aircraft clearance criteria do not apply. In areas where protection against lightning-induced surges is required, use surge arresters specifically designed for use at 400 Hz for protection of underground-to-aerial risers. The use of 60-Hz arresters is ineffective and hazardous because of the capacitive elements of arresters. The change in frequency changes the capacitance and, therefore, disturbs the even-voltage gradients which prevent premature sparkover.

3.2.2 PRACTICABLE DISTRIBUTION AREA. Considering the 15,000-foot limit on the length of a medium-voltage feeder and the impracticality of straight-path feeder installations, the central plant service area is likely to be limited to a 2.5-mile radius.

Therefore, site configurations permitting one central plant should serve an area up to 5 miles in diameter.

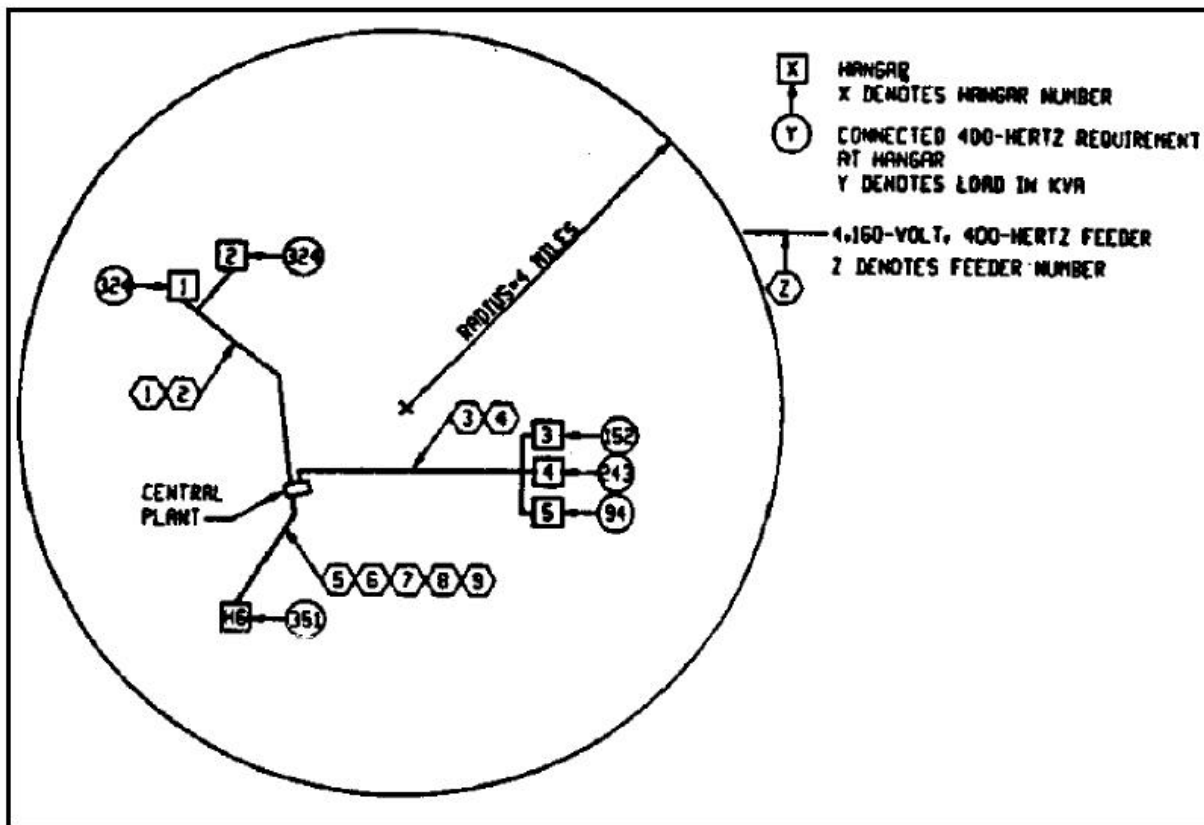

Figure 2

Example of Central Plant/Hangar Site Plan

3.2.3 SHUNT REACTOR CAPACITY. Install shunt reactors on each medium-voltage feeder to balance the capacitance of that feeder. Size the reactor so that the no-load power factor of each medium-voltage feeder, and thus the system, is close to unity. The nominal kilovoltampere reactive (kvar) rating of each reactor must be greater than its feeder cable's capacitive kvar to provide a lagging power factor, but it should not be more than 10 kvar as seen by the overall system. Indicate nominal ratings based on the maximum allowable specified capacitance of each medium-voltage feeder. Install shunt reactors on each medium-voltage feeder as indicated on Figure 1.

3.2.3.1 FIELD ADJUSTMENT. Adjust the nominal indicated rating of the shunt reactor to suit the actual capacitance of the cable provided. Make field measurement of the actual capacitance after the cable is installed, and the correct shunt reactor tap can be chosen to the closest unity power factor setting.

3.2.3.2 NOMINAL RATING SIZING. An example of nominal shunt reactor sizing follows. If the nominal rating calculated is less than 10 kvar for a feeder, the shunt reactor may not be necessary to decrease voltage drop. However, its installation provides for capacitive discharge which increases operator safety.

System voltage (V.S-) = 4,160 volts

Feeder Length = 1 mile

Maximum capacitance allowed = 0.603 microfarads per mile

Capacitive reactance (X.C-) = -j660 ohms at 400 hertz

$$\text{Nominal rating} = \frac{V.S- \text{ squared}}{1,000X.C-} = \frac{(4,160) \text{ squared}}{1,000 (660)} = 26.2$$

Required nominal rating = 26.2 kvars

3.3 CENTRAL PLANT DESIGN. A central plant is the point where the station's medium-voltage distribution system 60-Hz (in rare cases 50-Hz) input is converted to 400-Hz power for distribution by a 400-Hz feeder distribution center to the station's medium-voltage distribution system. A typical 400-Hz central plant is shown on Figure 3. Normally, the plant will be an unmanned facility.

3.3.1 RELIABILITY. The continuous operation of the central 400-Hz medium-voltage system is extremely critical. Standby components are required at the central plant to ensure no major loss of 400-Hz electric power.

3.3.2 SYSTEM 60-HERTZ INPUT POWER. The design of the 60-Hz input system is covered in this handbook only to the extent of providing necessary 400-Hz system reliability. For this reliability, two primary inputs from different feeders or electric sources of 60-Hz electric power are required at the central plant.

3.3.2.1 PRIMARY FEEDER SOURCE. Generally, provide a prime and an alternate feeder from the installation's 60-Hz primary (medium-voltage) distribution system. An area having a 400-Hz load large enough to require a central medium-voltage system is an area with a load density which is both large and sufficiently important enough to require more than one 60-Hz primary distribution feeder.

3.3.2.2 DIESEL-ENGINE GENERATOR SOURCE. Provide an emergency diesel-engine generator system as the alternative source where provision for an alternative feeder is more costly than a standby power system. Provide diesel-engine generator capacity of at least 80 percent of the frequency conversion plant's firm capacity. Frequency conversion plant firm capacity is the sum of the rated capacities of all frequency conversion assemblies, with the largest unit not operating. Where required by the activity, provide 100-percent diesel-engine generator capacity. Provide diesel-engine generator sets with both manual and automatic transfer modes which start automatically on loss of normal power. Where more than one diesel-engine generator set is provided, provide units capable of being automatically paralleled. Provide switches to permit testing of diesel-engine generators without assuming load. The most economical diesel-engine generator voltage is generally the input voltage to the frequency conversion assembly.

3.3.2.3 TRANSFORMER. Because the frequency conversion assemblies are low-voltage input devices, transformers are necessary to stepdown primary power. No facility should depend on only one transformer, since this can result in a complete shutdown of the 400-Hz system. Require duality of transformers. Each transformer's rating shall be not less than 80 percent of the frequency conversion plant's firm capacity. When transformers of the outdoor substation type are installed adjacent to the central plant as shown on Figure 3, they can be used to supply the central plant's 60-Hz low-voltage switchboard as shown on Figure 4.

3.3.3 SYSTEM 400-HERTZ CONVERSION CAPACITY. Firm power is power which is available even under emergency conditions. Determine the firm frequency conversion capacity of the central plant by the loads served and a 15- to 20-percent additional capacity for future loads. Provide one extra unit for standby (i.e., emergency use). If the requirement for the standby unit and for future capacity necessitates more units than for the present load with maintenance backup, incremental construction may be desirable. Such planning is acceptable as long as future space and capacity provisions for ancillary devices are covered fully in the first-design stage.

3.3.4 FREQUENCY CONVERSION ASSEMBLIES. Ratings as shown in Table 3 provide satisfactory operation. When frequency conversion assembly performance is combined with a properly designed distribution and utilization system, it provides 400-Hz power to aircraft loads. Figure 5 shows a typical frequency conversion assembly.

3.3.4.1 MOTOR GENERATOR UNITS. Use standard units manufactured to support both military and commercial airports.

a) Output voltage. The most preferable output voltage is that of the distribution system or 4,160 volts; however, this equipment is not yet commercially available. Normally, specify a 575-volt motor generator output, except when the system can reuse existing motor-generator sets that meet, or can be adapted to meet, criteria. In such cases use new motor-generator sets which match the output voltage of the existing sets.

b) Unit capacity. Normally, provide 312-kVA generators (the largest capacity now being produced as a standard by more than one manufacturer), since this size is usually the most economical and has the maximum full load efficiency (see Table 9). Use other unit capacities when adequately justified.

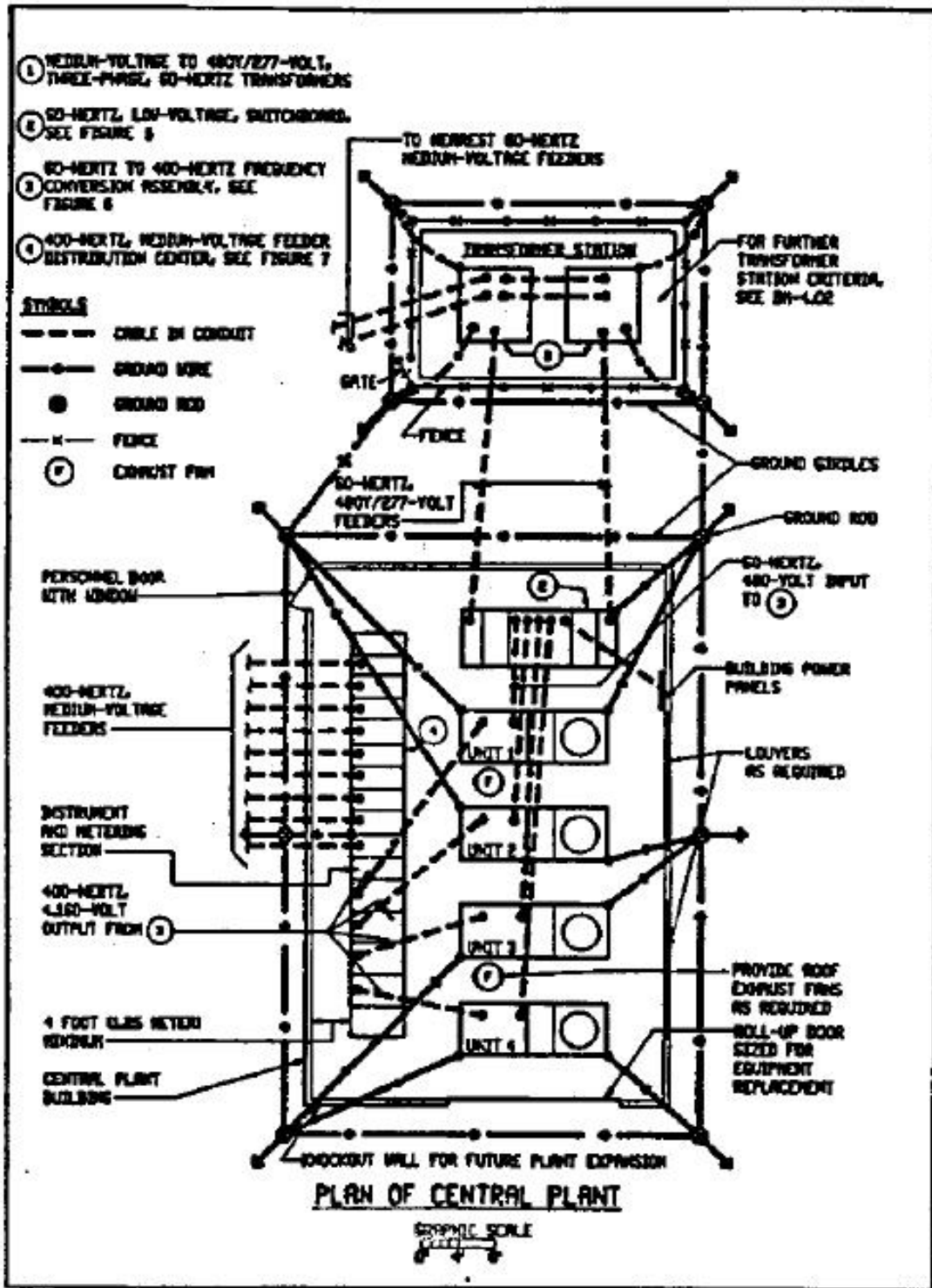

Figure 3
Typical 400 Hz central plant

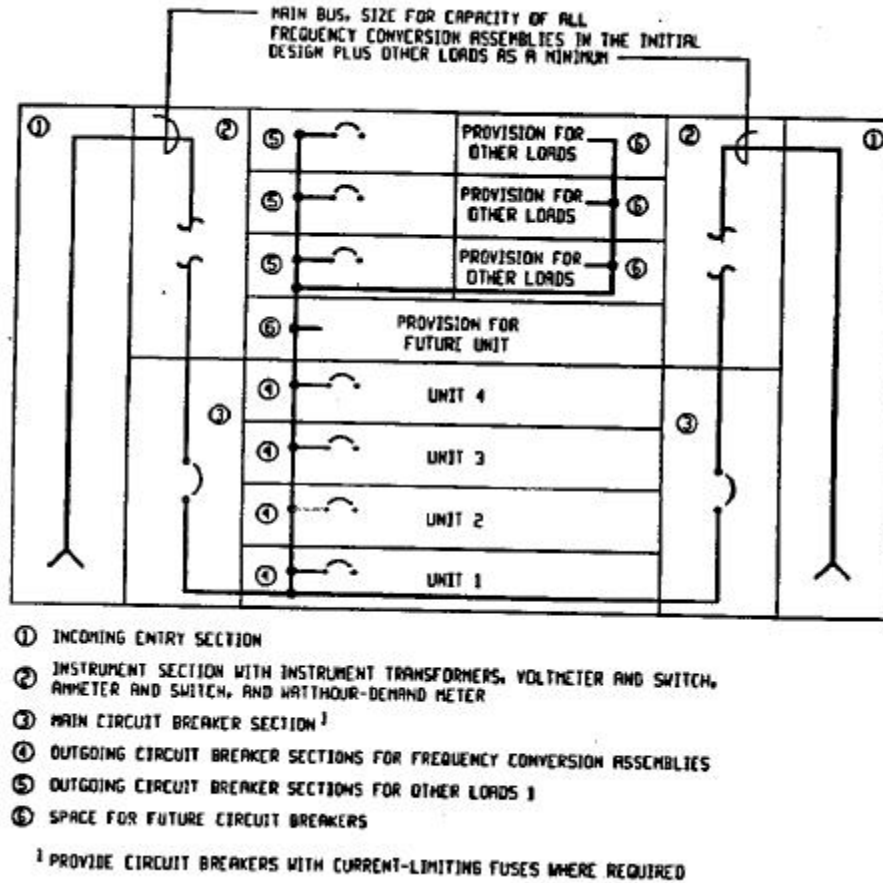

Figure 4

Single line diagram of a 60 Hz low voltage switchboard

c) Vertical shaft construction. Vertical-shaft construction minimizes floor space requirements. A 312-kVA vertical motor-generator set, weighing as much as 6 tons (5500 kilograms), is approximately 4 feet (1.2 meters) square by 6.5 feet (1.98 meters) high. The same size horizontal unit can require a 6-foot (1.8 meters) by 7-foot (2.1 meters) floor space and can be almost as high. These areas and loads do not include the rest of the assembly requirements. Provide a clear space of at least 3 feet (0.9 meter) above the motor generator to allow for maintenance of the vertical unit.

Input Horsepower (1)	Efficiency		Percent
	kVA	kW	
400	312	250	88
300	250	200	87
250	219	175	86
250	187	150	85
200	156	125	83
150	125	100	80
100	93.8	75	78
100	75	60	76
75	62.5	50	75

(1) Nearest standard size. Actual input horsepower may vary, depending upon the individual manufacturer.

Table 9
Typical full-load efficiencies

3.3.4.2 OTHER COMPONENTS. Figure 5 shows the other components that are provided as a part of a packaged frequency conversion unit. This ensures that units are factory designed to meet performance requirements.

a) Voltage step-up. Match the kVA of the low-to-medium-voltage step-up transformer specifically to the generator capacity. Provide voltage sensing devices on the transformer output to regulate the voltage of the motor-generator set. This regulation ensures that the voltage level at the medium-voltage bus of the 400-Hz feeder distribution center remains constant under any steady-state load condition.

b) Output disconnect. Use a vacuum contactor to disconnect the output of the unit rather than a circuit breaker, because the contactor is both smaller and less costly. In addition to overload and short-circuit protection, a contactor can provide overvoltage, undervoltage, underfrequency, and reverse-power control features, which are not available from a fused switch.

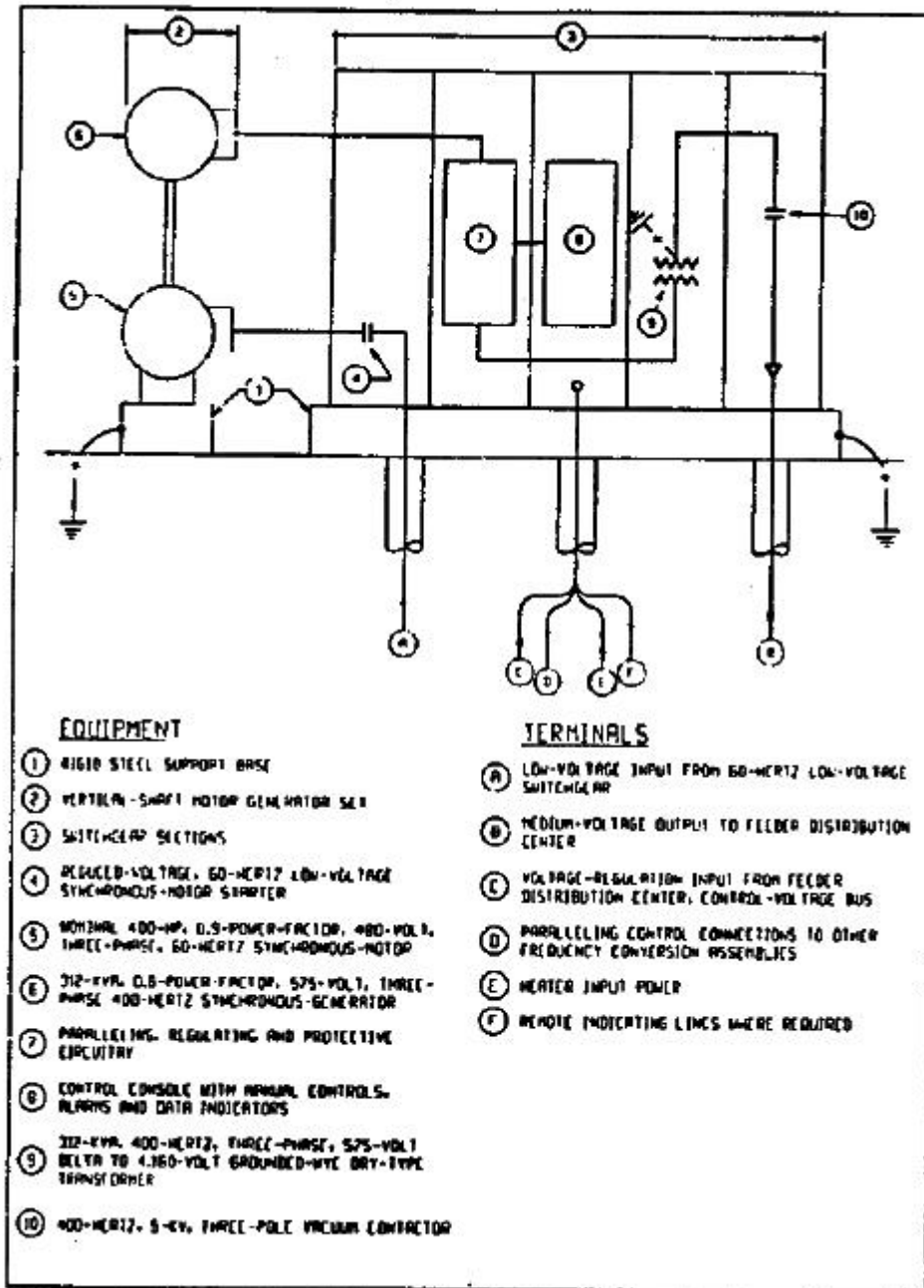
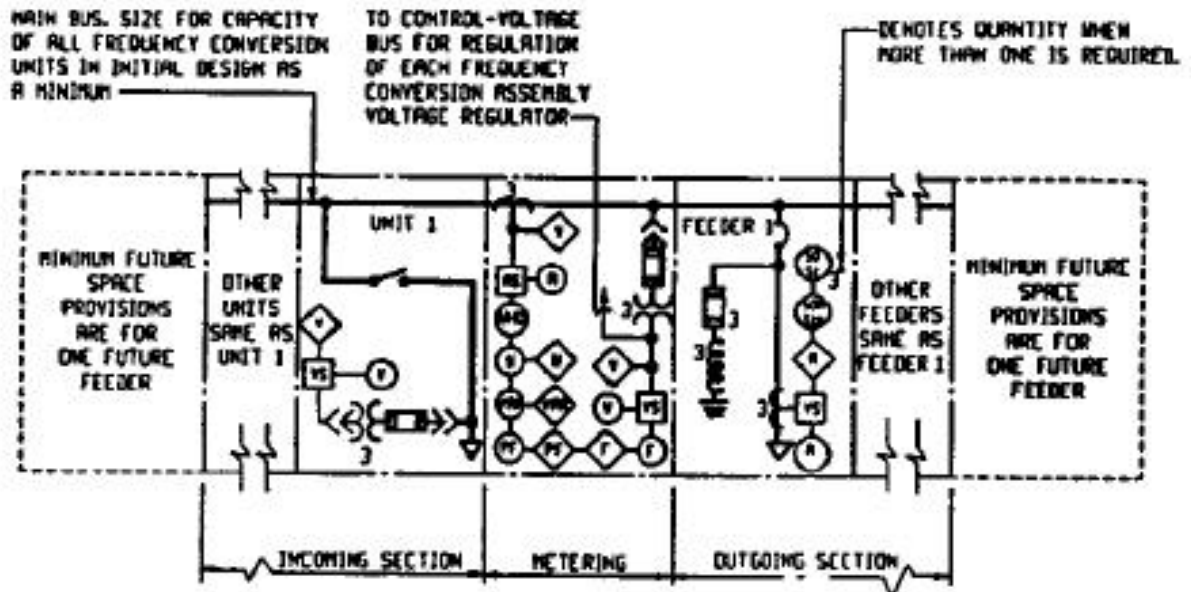

Figure 5

Single line diagram of a frequency conversion assembly



LEGEND

——— MEDIUM-VOLTAGE 400-HERTZ
 ——— LOW-VOLTAGE CONTROL

SYMBOLS

- | | | | |
|--|-----------------------------------|-------------------------|--|
| | LOAD-INTERRUPTER ISOLATION SWITCH | | INSTANTANEOUS AND TIME OVERCURRENT RELAY PROTECTION, PHASE AND NEUTRAL |
| | VACUUM CIRCUIT BREAKER | | TRANSFER SWITCH, CURRENT AND VOLTAGE |
| | CURRENT TRANSFORMER | METER TRANSDUCER | |
| | VOLTAGE TRANSFORMER | | AMPERES |
| | SHUNT REACTOR | | FREQUENCY |
| | FUSE | | POWER FACTOR |
| | MEDIUM-VOLTAGE CABLE TERMINATION | | VOLTS |
| | | | VARS |
| | | | WATTS |
| | | | WATT-HOUR - DEMAND |

Figure 6
Single line diagram of a feeder distribution center

3.3.5 FEEDER DISTRIBUTION CENTER. The feeder distribution center serves as the 400-Hz medium-voltage system control point. Feed the output of all the frequency conversion assemblies into a common bus which supplies all the 400-Hz medium-voltage feeders. It serves as a point to measure 400-Hz usage and to correct the system's no-load power factor to almost unity by balancing the capacitance of each feeder cable. Figure 6 shows a typical feeder distribution center.

3.3.5.1 METERING. Normally, do not install recording type meters in an unmanned facility. If records are required, transmit them to a point where personnel are available to maintain orderly record keeping and storage.

3.3.5.2 SHUNT REACTORS. An example of shunt reactors sizing is shown.

3.3.6 CENTRAL PLANT BUILDINGS AND OTHER EQUIPMENT SHELTERS. The same reliability standards cited for equipment shall also apply to structures sheltering any part of the 400-Hz system or its environmental support systems. Provide spaces around equipment for ease and convenience of testing, maintenance, serving, and equipment removal. Provide a minimum 5-foot (1.5-meter) aisle space around each frequency conversion assembly. Larger aisles may be required to allow for replacement of defective equipment. Design buildings with knockout panels for future expansion. Control mechanical systems automatically by thermostats which maintain correct temperatures under all operating conditions. Provide roof exhaust fans as required. Provide louvers and air handling units for air supply which have filters which prevent entrance of dusty air into the operating parts of the motor-generator sets. Include other considerations normally provided for diesel-engine generators and switchgear rooms.

3.4 LOW-VOLTAGE UTILIZATION SYSTEM DESIGN. A low-voltage utilization system extends from the utilization service assembly as shown in Figure 1 or from the solid state frequency conversion assembly as shown in Figures 1a and 1b to the parked aircraft. The layout of aircraft parking defines the location of the parked aircraft units which will define the locations and number of utilization service assemblies or solid state

frequency conversion assemblies and determine if a single, low or medium-voltage feeder is capable of supplying only one hangar, several hangars, or aprons. Integrated design with the aircraft fixed point utility systems.

3.4.1 LOW-VOLTAGE SYSTEM EQUIPMENT. In addition to a utilization service assembly as used on a medium voltage system, each low-voltage system includes the individual aircraft's supply source or fixed service point unit.

3.4.1.1 UTILIZATION SERVICE ASSEMBLIES. To assure satisfactory operation, provide utilization service assemblies with components as shown on Figure 7.

a) Step-down transformers. Normally, provide step-down transformers rated 75 kVA and with a three-phase 208Y/120-volt output. The terminal rating of 208Y/120 volts is consistent with the usually higher voltage rating of distribution equipment over the typical 200Y/115 volts of utilization equipment. The higher distribution voltage level allows for voltage drop between the distribution and utilization points. The load served is generally no more than two, 100-ampere, 0.8-power-factor unit loads (34.5 kVA each). In special cases, larger load requirements may have to be served. In such cases, criteria shall be provided by the using agency to the designer. For TACAMO loads, utilize 400 kVA transformers with the same maximum percentage impedance values shown in Table 4 for 75-kVA units.

b) Line drop compensators. Set the medium-voltage feeder length to give a per-unit voltage droop (absolute change in voltage between steady state, no-load and steady state, full-load) to 0.942 at the end of the feeder cable or 113-volts line-to-neutral on a 120-volt utilization assembly terminal voltage base. Therefore, compensate the drop from the utilization service assembly to the aircraft connector so that no less than 113 volts are provided to the aircraft at the interface point. Provide line drop compensators as indicated in Table 4 for 75-kVA transformers and 460 to 480 kVA for 400-kVA transformers.

c) Passive-element filter assembly. Install Passive-element filter assemblies to reduce harmonics which can be generated in the system. Standard performance requirements are based on systems which do not provide additional harmonics from the presence of rectified direct-current loads. Provide passive-element filters on equipment terminals of an aircraft whose load produces harmonics.

3.4.1.2 FIXED SERVICE POINT UNITS. Generally, fixed service point units provide disconnecting devices for two aircraft; that is, they provide two circuit breakers.

3.4.2 LOW-VOLTAGE CABLE LIMITATIONS. The location of the parked aircraft and the 60-foot aircraft cable limits the location of fixed service point units. Each fixed service point unit requires a utilization service assembly or solid state frequency converter for its supply, with the location limited by the maximum 250-foot service cable length. For medium-voltage systems, the voltage level on the input to the utilization service assembly defines the setting for its line drop compensator. Indicate compensator settings on the drawings so correct aircraft voltage levels are provided. Overcompensation can cause the sending-end impedance to appear very low and result in a current flow that can raise the voltage level above the required 118 volts. Set the compensator so that the limits of 113 volts minimum at full-load and 118 volts maximum at no-load at the aircraft interface point is not compromised under any circumstance.

3.4.3 FEEDER CABLE CONNECTION. Once the location of all utilization service assemblies is determined, calculate the allowable number of such devices which can be connected to a medium-voltage feeder cable.

3.4.4 CABLE DESIGN REQUIREMENTS. Cable for 400-Hz circuits requires a design which minimizes voltage drop by its construction. The cable parameters for feeder and service cable are given in Table 5. To provide standardized design, design aircraft cable to meet requirements in MIL-STD-90328, Cable Assembly External Electric Power. Aircraft 115/200-Volt, 400-Hz.

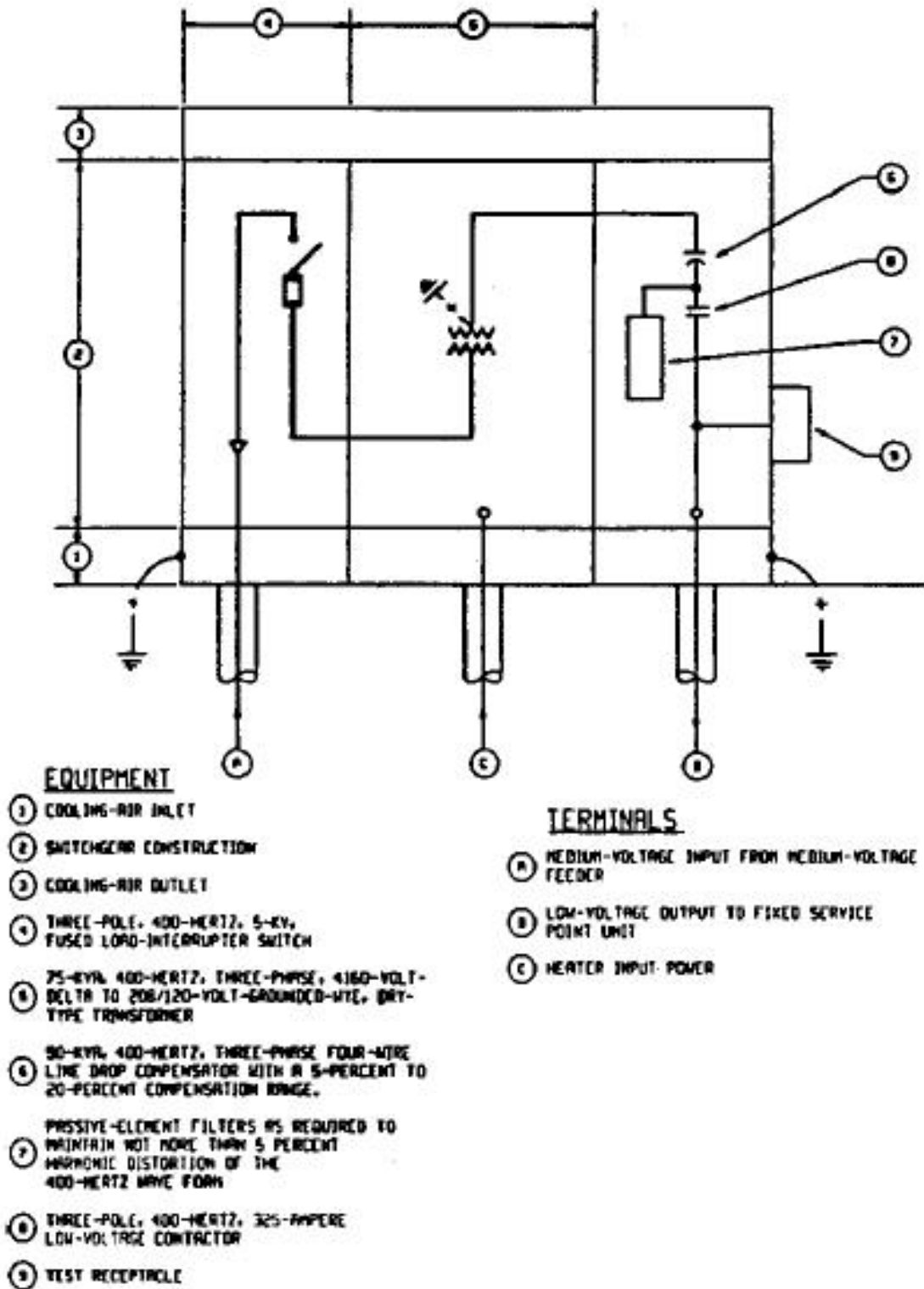

Figure 7
Single line diagram of a utilization service assembly

QUIZ

AN INTRODUCTION TO 400 HZ ELECTRICAL DISTRIBUTION SYSTEMS

1. _____ equipment generally operates at an input of 400 Hz.
 - a. Inductive power
 - b. Cathodic protection
 - c. Solid state digital
 - d. Aerospace electrical

2. Systems supplying 400 Hz for ground-power operations use frequency conversion equipment to change 60-Hz input to 400-Hz output. Rotary converters (motor generator sets) or _____ are used for this purpose.
 - a. solid state converters
 - b. rectifiers
 - c. power reactors
 - d. rheostats

3. Fixed service point units to which avionics equipment and aircraft are connected are supplied from either nearby frequency conversion assemblies over a low-voltage feeder system or from a more remotely located 400-Hz central plant using _____ feeders.
 - a. low voltage
 - b. medium voltage
 - c. high voltage
 - d. ungrounded

4. Generally low-voltage systems distribute voltages less than 600 volts. Because the _____ of an electric system is greater at 400 Hz than at 60 Hz, attention must be given to both circuit length and conductor size to maintain acceptable voltage regulation.
 - a. resistivity
 - b. reluctance
 - c. reactance
 - d. impedance

5. Full load efficiency of the motor-generator set portion of frequency conversion assemblies ranges from _____ percent, depending on the size of the sets and the type of motor drive (induction or synchronous).

- a. 15 to 110
- b. 73 to 88
- c. 50 to 75
- d. 33 to 61

6. Various types of loads require 400-Hz electric-power input. The power factor of these loads varies from _____ .

- a. 50 to 75
- b. 75 to 100
- c. 0.5 to 0.6
- d. 0.8 to 1.0

7. The inductive contribution to the reactance voltage drop of 400-Hz systems is roughly _____ times greater than that of 60-Hz systems, which necessitates certain modifications to conventional distribution and utilization system design to compensate for the increased voltage drop

- a. 7
- b. 6
- c. 5
- d. 4

8. The designer must consider maximum loads and applicable cable-length limitations. Based on acceptable end-voltage requirements, determine maximum allowable cable and equipment impedances. Methods to be used for compensation or elimination of _____ are important also. Overcompensation of voltage drop can be as bad as under compensation.

- a. amppliance
- b. resistance
- c. reluctance
- d. impedance

9. The voltage range of 108 volts minimum to 118 volts maximum specified is the operating voltage range of the equipment inside an aircraft. This operating voltage range takes into account a 0- to 5-volt drop in the electrical distribution system inside the aircraft. Accordingly, the full-load and no-load voltage at the interface (aircraft connection input point) should never drop below _____ volts nor rise higher than 118 volts.

- a. 107
- b. 109
- c. 111
- d. 113

10. Commercial airports are using 400-Hz systems with voltages up to _____ .

- a. 480 volts
- b. 2400 volts
- c. 4160 volts
- d. 12 kV

11. The 400-Hz system consists of the following major elements: a) The central power plant; b) The medium-voltage distribution system and c) The low-voltage _____ system.

- a. equipment power
- b. control
- c. distribution
- d. utilization

12. Always consider the thermal and magnetic characteristics for 400-Hz circuit protective devices. Operation at 400 Hz causes more heat rise in current-carrying parts than does operation at 60 Hz. There is also decreased electromagnetic pull on _____ elements.

- a. reverse polarity
- b. magnetic-trip
- c. resistance heating
- d. power interrupter

13. Provide surge arresters for 60-Hz system protection where necessary. In general, the only exposed lines will be those of the 60-Hz distribution system. Therefore, provide 400-Hz protection only for devices whose insulation capability is below that provided by the 60-Hz surge protection, which will normally protect the medium-voltage 400-Hz devices. Varistors available for use with the low-voltage 400-Hz system can limit surges to about 1.7 times the peak voltage; provide where required.

- a. 1.2
- b. 1.7
- c. 2.1
- d. 2.5

14. The presence of magnetic materials in the vicinity of electric conductors increases the _____ thereby increasing resistance and inductance. Therefore, use nonmagnetic materials, such as aluminum or plastic, for all raceways.

- a. flux density
- b. capacitance
- c. conductivity
- d. impedance

15. Install _____ on each medium-voltage feeder to balance the capacitance of that feeder.

- a. induction coils
- b. shunt reactors
- c. rheostats
- d. grounding coils